

OWNER'S MANUAL & FITTING INSTRUCTIONS

ORSS CARTRIDGE WP

122-018-155-085



RECOMMENDED SETTINGS

Oil Quantity	180-220ml*
Fork Oil	5wt
Spring	385-580-XXX
Spring Preload	12mm
Fork Position	See Manufacturer's Specification.

*USING OIL LEVELS OTHER THAN K-TECH RECOMMENDED QUANTITY MAY RESULT IN DAMAGE TO THE CARTRIDGE KIT AND/OR FORK

INTRODUCTION

The K-Tech Off Road Spring System has been designed to replace the air system in the latest off road motorcycles, this simple design allows you to remove the original air spring system and replace it with a more conventional spring system. This direct replacement spring system requires no machining to install and also features external spring preload adjustment.

- Spring preload adjustment
- Direct replacement (No machining required)
- Hard chrome piston rod
- Aircraft grade aluminium parts
- Wide range of spring rates available

K-Tech Suspension Ltd products are manufactured to fit specific brands and models. Under no circumstances should any K-Tech Suspension Ltd products be fitted to an application other than that for which it has been designed, tested and manufactured.

ORSS FRONT FORK CARTRIDGE



The front forks are a very important part of the motorcycle and will affect the safety and stability.



Read the instructions carefully and make sure you understand them before you proceed. If you have any queries please contact your dealer or nearest supplier of K-Tech Suspension immediately.



K-Tech Suspension Ltd. cannot be held responsible for any damage to vehicle, front fork, personal injury or property if the installation instructions are not followed exactly.



The Cartridge Kit only fits into the **LEFT HAND FORK LEG** and must only be fit into this leg.

These procedures should only be carried out by a qualified motorcycle technician. K-Tech Suspension Ltd will not be liable for any damages caused in any way to/ by the product and any injuries sustained if the product is fitted by someone who is neither an authorised dealer of K-Tech Suspension Ltd or have the relevant qualifications in motorcycle technology. K-Tech Suspension Ltd will also not be liable if the correct tools are not used throughout the process of fitting and adjustment of a K-Tech suspension Ltd product. Please refer to the manufacturer's workshop manual before attempting this procedure.

You will need to remove the front forks from the bike before fitting the cartridge, consult the manufacturer's workshop manual to do this.

*****This product is not designed or intended for highway use.*****

ORSS FRONT FORK CARTRIDGE

ADJUSTMENT

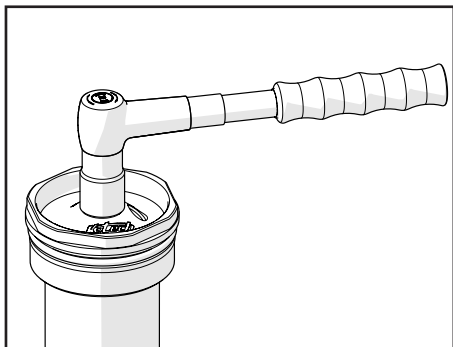

Preload Adjustment:-

Adjust using 12mm socket on the hex in the centre of the top cap.

Adjustment range is 18 turns.

All settings should be made from the fully out (anti-clockwise) position.

FITTING THE CARTRIDGE

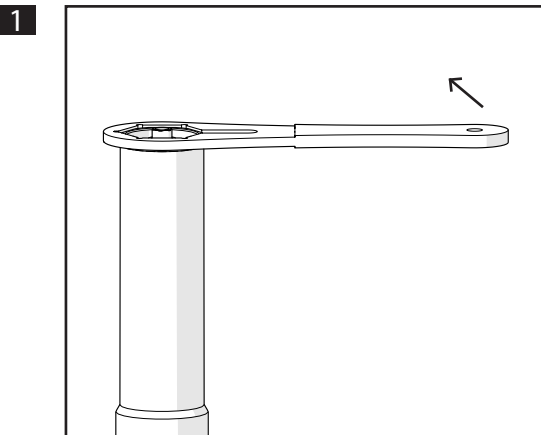

113-010-060 is provided with every kit.

Loosen off the Standard top Cap and unscrew from the outer tube using the top cap tool (113-010-060)

FITTING THE CARTRIDGE

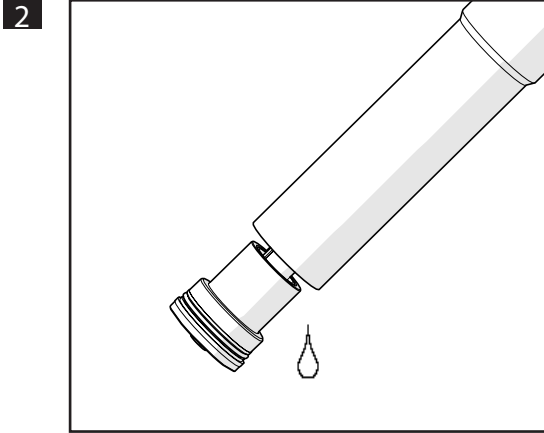

Make sure you have a suitable container to catch the oil.

Empty out the oil inside the fork leg by tipping it up and letting the oil drain out.

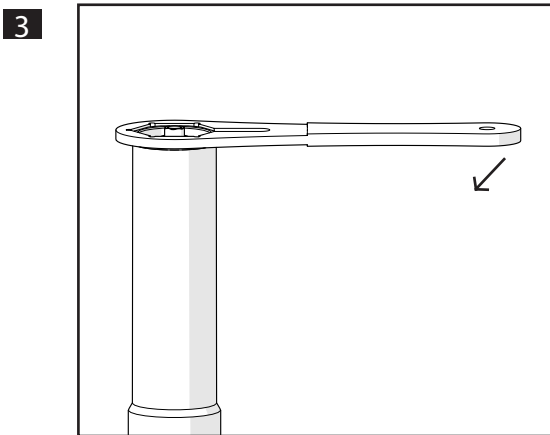

Screw the top cap back onto the outer tube but do not tighten up.

FITTING THE CARTRIDGE

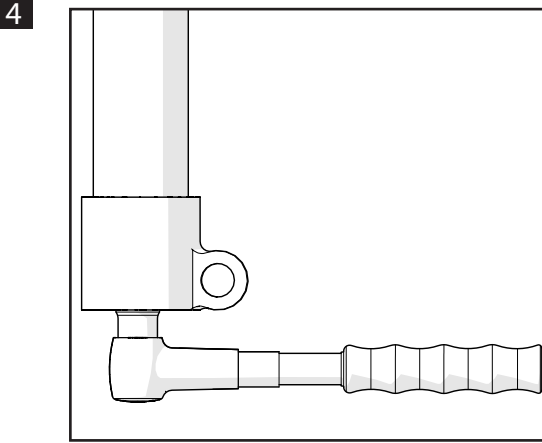

Any Oil still in the fork leg may drain out of the fork bottom when doing this. Make sure you have a suitable container underneath.

Unscrew the Base Valve from the bottom of the fork bottom using an 7mm allen key.

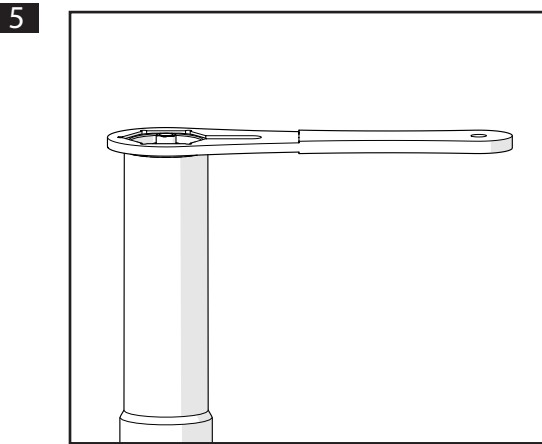

Remove the top cap from the outer tube using the top cap tool (113-010-060)

FITTING THE CARTRIDGE

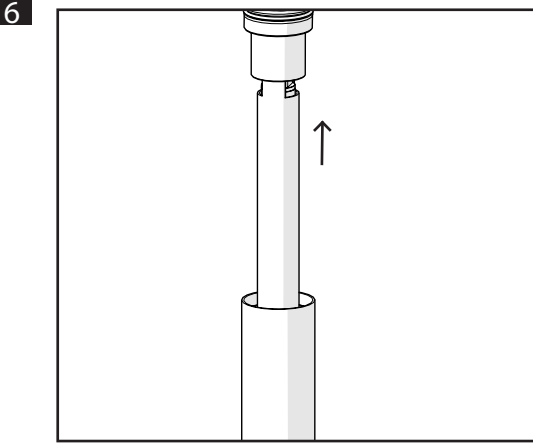

Remove the standard cartridge from the forks by pulling the top cap up and out of the forks.

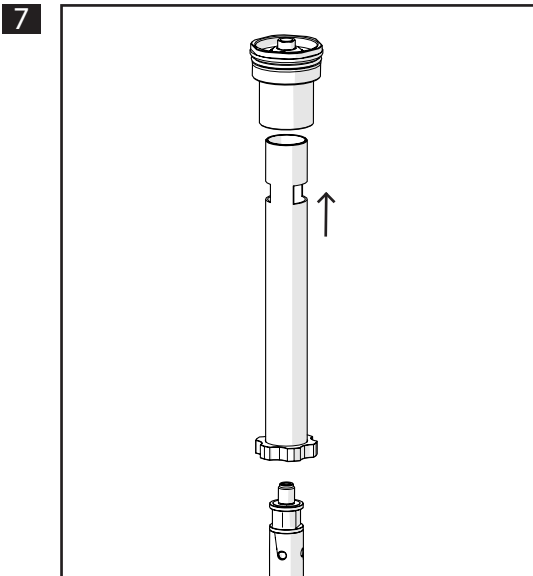

You are now ready to fit the K-Tech cartridge.

Remove the Top cap and preload spacer from the K-Tech cartridge.

FITTING THE CARTRIDGE

8

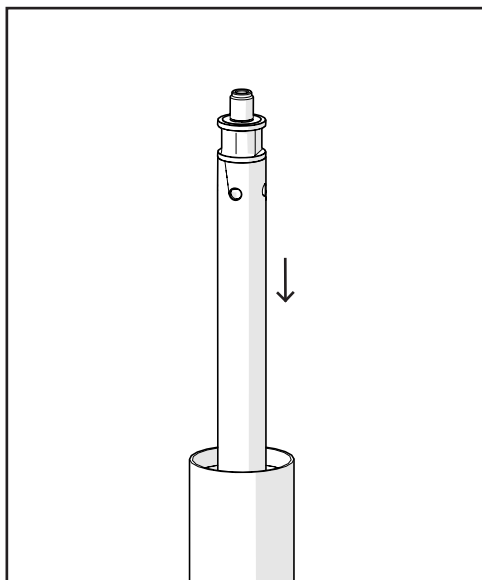

Install the K-Tech cartridge into the fork tube.

9

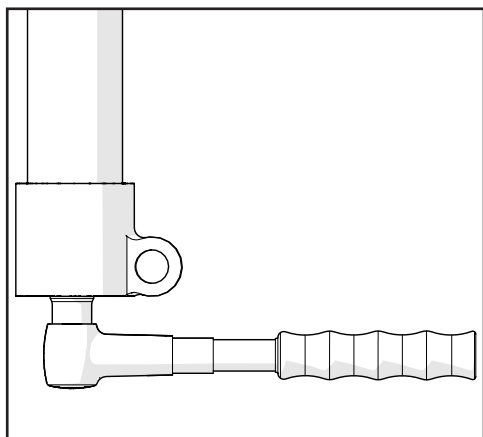

Install the base valve into the fork bottom. Torque the base valve to 40Nm using a 7mm allen key.

8

FITTING THE CARTRIDGE

10

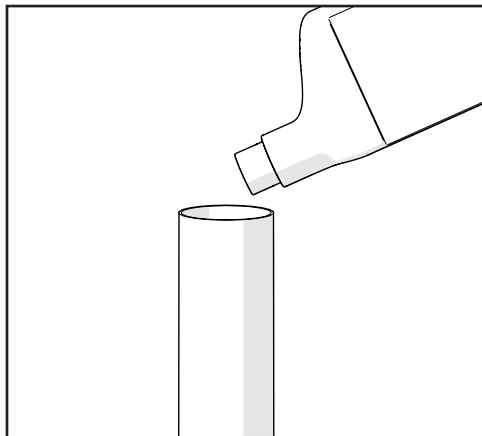

Pour fork oil into the fork leg.

11

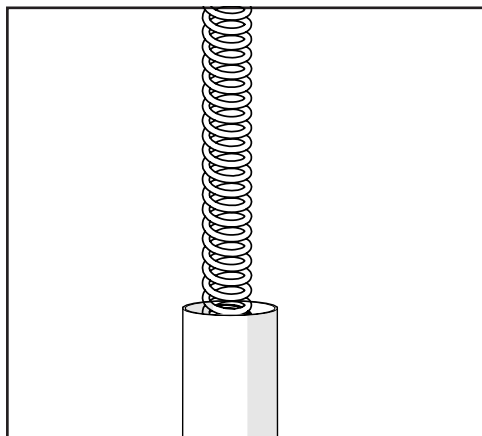

Install the chosen spring into the fork leg.

FITTING THE CARTRIDGE

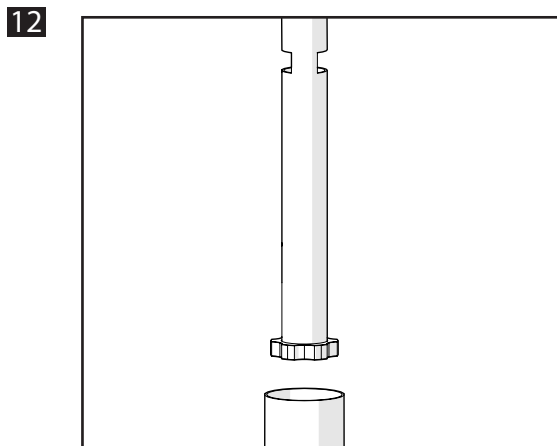

Make sure the slots go towards the top of the forks.

Install the spring preload spacer along with the spring pusher attached to the bottom.

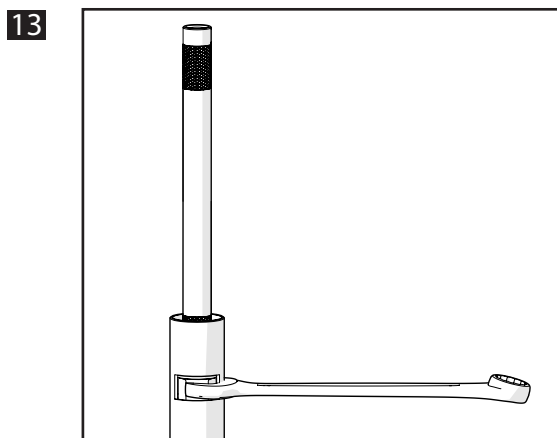

113-030-015 is provided in every kit.

Pull the piston rod up using pull up rod tool (113-030-015). Use an 18mm spanner to hold it in place through the slots on the preload tube.

FITTING THE CARTRIDGE

14

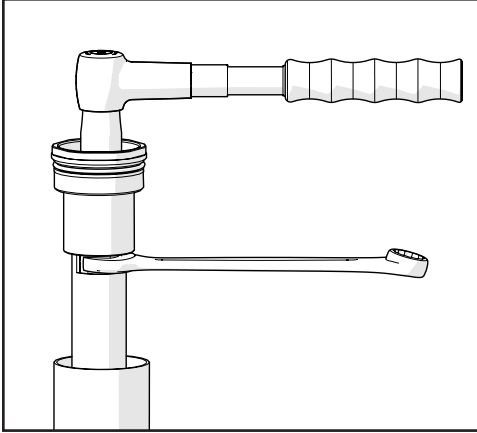

Remove the pull up rod tool (113-030-015) and install the top cap assembly. Screw the top cap onto the rod joiner and torque to 20Nm using a 12mm Socket.

15

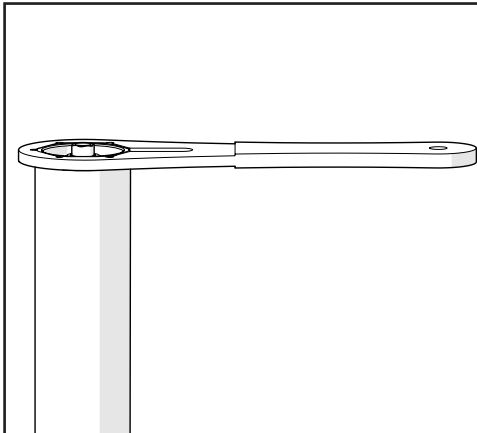

Apply Green Grease (FF-GREASE) to the top cap o-ring before installing.

Pull the outer tube up to the top cap and screw on. Tighten the top cap onto the tube using the top cap spanner (113-010-060)

FITTING THE CARTRIDGE

- 16 Install the forks and wheel back into the bike with the preload adjuster wound fully out.

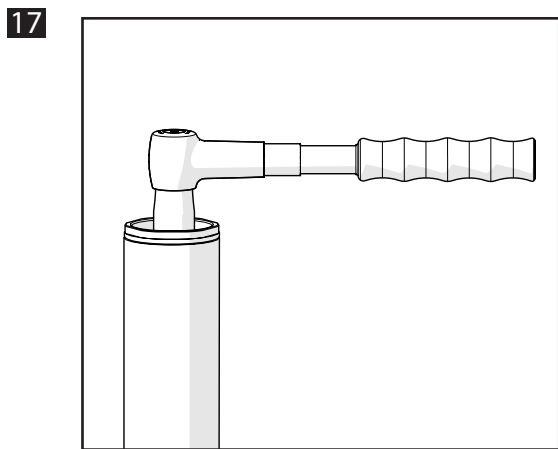

Preload must be set after the forks and wheel are installed into the bike, If not the wheel spindle will not be aligned.

Set the preload using a 12mm socket on the hex in the centre of the top cap. All adjustment range should be made from the fully out position (Anti-Clockwise). 1 full turn = 1mm adjustment.

SERVICE

K-Tech Suspension Ltd recommend that this product is serviced every 30 hours of use. It is very important that this product is serviced by an authorised dealer, as there are special tools required to guarantee correct performance of this product. K-Tech Suspension Ltd cannot be held responsible for any damage caused to/by the product if a service is overdue or was not conducted by an authorised dealer.



www.ktechsuspension.com

Contact your local K-Tech dealer for more details at
www.ktechsuspension.com/service-centres-and-partners